

Racing Lane Storage Reels

Prices subject to change without notice.



WALTERS' SWIM SUPPLIES, INC.

Website: www.walterswim.com Email: walterswim@sbcglobal.net

In WI: 1-262-790-9199 Fax: 1-262-790-9043 Toll Free: 1-800-558-0428



Lane Storage Reel by Paragon

Light weight yet rugged stainless steel construction with individual total lock caster brakes. Holds up to 540' of lane lines and requires little maintenance. The ideal lane storage reel for commercial and institutional pools. One-year warranty on all components other than casters.

| | | <u>Each</u> | <u>2+</u> |
|----------|---|-------------|-----------|
| #75101 | Lane Storage Reel | \$1293.20 | \$1218.00 |
| #75101SS | Lane Storage Reel w/Stainless Steel Casters | 1601.85 | 1508.70 |
| #75111 | Large Lane Reel (Holds an extra 180') | 1416.65 | 1334.30 |
| #75111SS | Large Lane Reel (Holds an extra 180') | 1725.30 | 1625.00 |
| #75133 | Lane Reel Cover (Fits Both Reels) | 192.55 | 181.40 |



Wave Eater™ Storage Reel System

The Wave Eater has the largest storage capacity on the market. The #304 stainless steel frame, black polyethylene discs and core assemble easily to make this the strongest and most durable lane storage system available. Large casters, equipped

with a locking device make the Wave Eater easy to roll. 5' x 5' x 6.5".
210300 Wave Eater \$1195.95

Wave Eater™ Cover

Heavy-duty reinforced cross link polyethylene cover provides lasting protection. 5' x 5' x 6.5'

210301 Wave Eater Cover \$104.95

STORAGE CAPACITY CHART

| | Wave Eater I & Advantage | Wave Eater II & Advantage II |
|----------|-----------------------------|---------------------------------|
| 60 Foot | 9 | 5 |
| 75 Foot | 7 | 4 |
| 25 Meter | 6 | 4 |
| 50 Meter | 3 | 2 |

ANTI-WAVE STORAGE REELS



Ultimate Storeel

You will love our new super-capacity, stunning looking, easy to handle lane Storeel - And you won't believe the incredible price!! We are proud to offer a Storage Reel large enough to hold a full set of lanes, at a price which will blow away the competition. Our new "Ultimate" Storeel is made of top quality coated aluminum (including the Wheels—not the flimsy plastic version you find on other Reels!), with a 6" diameter center spool (designed to eliminate the possibility of damage to the discs), and with a spool width of 79 inches (or SIX FEET SEVEN INCHES WIDE). We of course have a 3-Year Warranty for the "Ultimate" Storeel.

| | <u>Each</u> | <u>2+</u> |
|--------|-------------|-----------|
| AW0615 | \$1155.70 | \$1078.65 |

with purchase of Antiwave Racing Lanes

| | <u>Each</u> | <u>2+</u> |
|---------|-------------|-----------|
| AW0615S | \$1098.55 | \$1025.30 |

| | <u>Each</u> | <u>2+</u> |
|---------------------------------------|-------------|-----------|
| Ultimate Storeel Mesh Cover AW0619 | \$118.60 | \$110.95 |

COMPETITOR® Stor-Lane® Reel

Stor-Lane Reel – for proper storage and easy installation and removal of Competitor Racing Lanes, the Stor-Lane Reel can accommodate up to 540' of 4" lanes + 330 ft. of 6" lanes. Designed for easy maneuverability around the pool, deck, using 5" swivel casters with individual brakes. The main framework is electroplated aluminum which supports the thermo formed plastic reel assembly. Overall dimensions are: 68" x 46" x 58".
Weight 110 lbs.
Color available: Blue.



REPLACEMENT PARTS AND HARDWARE

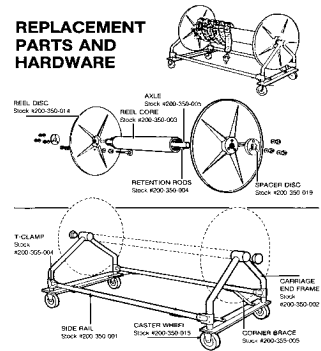

Stor-Lane® Reel Cover

Stor-Lane Reel Cover – to maintain proper storage of your Stor-Lane Reel and Racing Lanes, this vinyl cover is a must. Made of Dark Blue tear resistant vinyl can be used for seasonal storage or everyday use. Protects the lanes from the damaging ultra violet rays, which over long periods can break down plastics. Weight 14 lbs.

| Part Number | Description | Each | 2+ |
|-------------|--------------------------------------|-----------|-----------|
| 200350 | Stor-Lane Reel Unassembled (110 lbs) | \$1531.40 | \$1429.30 |
| 200351 | Stor-Lane Reel Cover (14 lbs) | 163.25 | 151.55 |

REEL ASSEMBLY

| Stock # | Description | Each | 2+ |
|-------------|--|----------|----------|
| 200-350-015 | Caster wheel with brake | \$ 47.40 | \$ 43.75 |
| 200-350-014 | Reel disc (must ship motor freight) | 230.95 | 214.45 |
| 200-350-019 | Spacer disc | 12.05 | 11.20 |
| 200-350-003 | Reel Core | 56.50 | 52.15 |
| 200-350-004 | Retention rods | 26.05 | 24.20 |
| 200-350-005 | Axle | 88.95 | 82.10 |
| 200-355-002 | Hardware Package B (complete hardware needed – nuts, bolts, washers, eye bolt and plastic axle plugs for reel assembly) | 23.70 | 22.05 |
| 200-350-001 | Side rail | 83.00 | 76.60 |
| 200-350-002 | Carriage end frame | 320.25 | 295.65 |
| 200-355-004 | T-clamp | 13.30 | 12.30 |
| 200-355-005 | Corner brace | 7.65 | 7.05 |
| 200-355-003 | Hardware Package C (contains 8 T-clamps and 4 corner braces used for carriage assembly, and instruction sheet. Order hardware Package A for assembly hardware) | 112.25 | 103.63 |
| 200-355-001 | Hardware Package A (Complete hardware needed – nuts, bolts, and washers – to assemble carriage) | 33.25 | 30.65 |